

2.4 GHz Cordless Telephone with Caller ID

Featuring Clarity[®] Power[™] Technology

Clarity C600 User Guide



CLARITY 
Amplifying Your Life[™]

Table of Contents

Safety Instructions	3	Telephone Operations	16
Features	5	Placing a Call	16
Getting Started	8	Answering a Call	16
Choosing a Location	8	Last Number Redial	16
Installation	8	Pause Feature	16
Battery Installation	10	Temporary Tone	17
Handset Battery Charging	10	Lighted Key Pad	17
Low Battery	10	Page/Handset Locator	17
Battery Life	10	Channel Operation	17
Headset Jack	11	Security Code	17
Belt Clip	11	Memory Storage	18
Hearing Aid Compatibility	11	Review Phonebook Information	18
Feature Set Up	12	Adding a Phonebook Number	18
Handset	12	Dialing a Phonebook Entry	19
Set Up Mode	12	Deleting a Stored Number	19
Clarity Power Technology	14	Deleting All Stored Numbers	19
Boost Clarity Power On/Off	14	Changing a Memory Number	19
Volume Control	14	Changing a Memory Number	19
Handset Ringer	14	Adding the Emergency Number	20
Telephone Base	14	Dialing the Emergency Number	20
Ringer Volume	14	Deleting the Emergency Number	20
Ringer Style	14	Caller ID Operations	21
Visual Ringers	14	Saving Caller ID Information	
Boost On/Off	15	to Phonebook	22
Pulse/Tone	15	Callback from Caller ID Information	23
Flash	15	Delete Caller ID Information	24
Mute	15	Maintenance and Care	25
Redial/Pause	15	Troubleshooting	26
Battery Backup	15	Regulatory Compliance	28
		Warranty and Service	31

Important Safety Instructions

When using your telephone equipment, basic safety precautions should always be followed to reduce the risk of fire, electric shock and injury to persons including the following:

1. Read and understand all instructions.
2. Follow all warnings and instructions marked on the telephone.
3. Do not use this telephone near a bath tub, wash basin, kitchen sink or laundry tub, in a wet basement, near a swimming pool or anywhere else there is water.
4. Avoid using a telephone (other than a cordless type) during a storm. There may be a remote risk of electrical shock from lightning.
5. Do not use the telephone to report a gas leak in the vicinity of the leak.
6. Unplug this telephone from the wall outlets before cleaning. Do not use liquid cleaners or aerosol cleaners on the telephone. Use a damp cloth for cleaning.
7. Place this telephone on a stable surface. Serious damage and/or injury may result if the telephone falls.
8. Do not cover the slots and openings on this telephone. This telephone should never be placed near or over a radiator or heat register. This telephone should not be placed in a built-in installation unless proper ventilation is provided.
9. Operate this telephone using the electrical voltage as stated on the base unit or in the owner's manual. If you are not sure of the voltage in your home, consult your dealer or local power company.
10. Do not place anything on the power cord. Install the telephone where no one will step or trip on the cord.
11. Do not overload wall outlets or extension cords as this can increase the risk of fire or electrical shock.
12. Never push any objects through the slots in the telephone. They can touch dangerous voltage points or short out parts that could result in a risk of fire or electrical shock. Never spill liquid of any kind on the telephone.
13. To reduce the risk of electrical shock, do not take this phone apart. Opening or removing covers may expose you to dangerous voltages or other risks. Incorrect reassembly can cause electric shock when the appliance is subsequently used.
14. Unplug this product from the wall outlet and refer servicing to the manufacturer under the following conditions:
 - A. When the power supply cord or plug is frayed or damaged.
 - B. If liquid has been spilled into the product.
 - C. If the telephone has been exposed to rain or water.
 - D. If the telephone does not operate normally by following the operating

SAVE THESE INSTRUCTIONS

Important Safety Instructions

instructions. Adjust only those controls that are covered by the operating instructions. Improper adjustment may require extensive work by a qualified technician to restore the telephone to normal operation.

- E. If the telephone has been dropped or the case has been damaged.
 - F. If the telephone exhibits a distinct change in performance.
15. Never install telephone wiring during a lightning storm.
 16. Never install telephone jacks in wet locations unless the jack is specifically designed for wet locations.
 17. Never touch uninsulated telephone wires or terminals unless the telephone line has been disconnected at the network interface.
 18. Use caution when installing or modifying telephone lines.
 19. Use only the power cord and batteries indicated in the manual. Do not dispose of batteries in a fire. They may explode. Check with local codes for possible special disposal instructions.
 20. Plug the AC adaptor into the outlet that is nearest and most accessible to the telephone.

Safety Instructions For Batteries

CAUTION: Risk of explosion if battery is replaced by an incorrect type. Dispose of used batteries according to the instructions.

1. Use only the approved battery pack in the handset of your cordless phone.

For Handset Unit: **3.6V 600mAh**
NiMH Rechargeable Battery
GP60AAAH3BMJZ
GPI International Ltd

For Base Unit: Four (4) AA alkaline batteries

2. Do not dispose of the battery in a fire as it may explode. Check with local codes for possible special disposal instructions.

3. Do not open or mutilate the battery. Released electrolyte is corrosive and may cause damage to the eyes and skin. It may be toxic if swallowed.
4. Exercise care in handling batteries in order not to short the battery with conducting materials such as rings, bracelets and keys. The battery or conduction material may overheat and cause burns.
5. Charge the battery (ies) provided with or identified for use with this product only in accordance with the instructions and limitations specified in this manual.
6. Observe proper polarity orientation between the battery pack and the battery charger.

SAVE THESE INSTRUCTIONS

Features

Handset

1. 2.5 mm Headset Jack
2. Key Pad
3. Handset Charging Contacts
4. DEL/Channel Button (DEL/CH)
5. Talk Button (TALK)
6. Mode Button (MODE)
7. Flash Button (FLASH)
8. Mute Button (MUTE)
9. Redial/Pause Button (RD/P)
10. Temporary Tone Button (*)
11. Handset Ringer Off/On
12. Neckloop Jack
13. Boost Button (BOOST)
14. Volume Control
15. Program Button (PROG)
16. Enter Button (ENTER)
17. Antenna/Visual Ringer

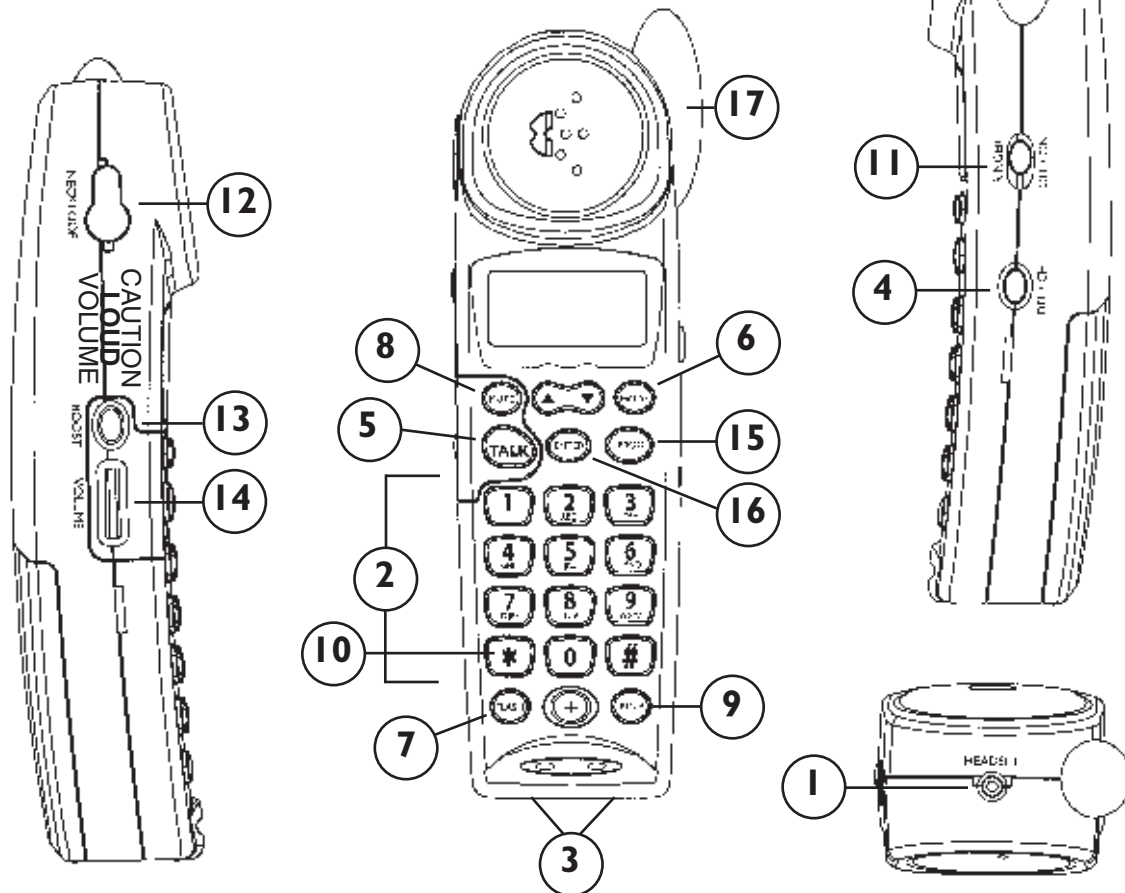

Features

Telephone Base

1. Charging Contacts
2. Base Antenna/Visual Ringer
3. Power LED
4. In Use LED
5. Charge LED
6. Page Button (PAGE)

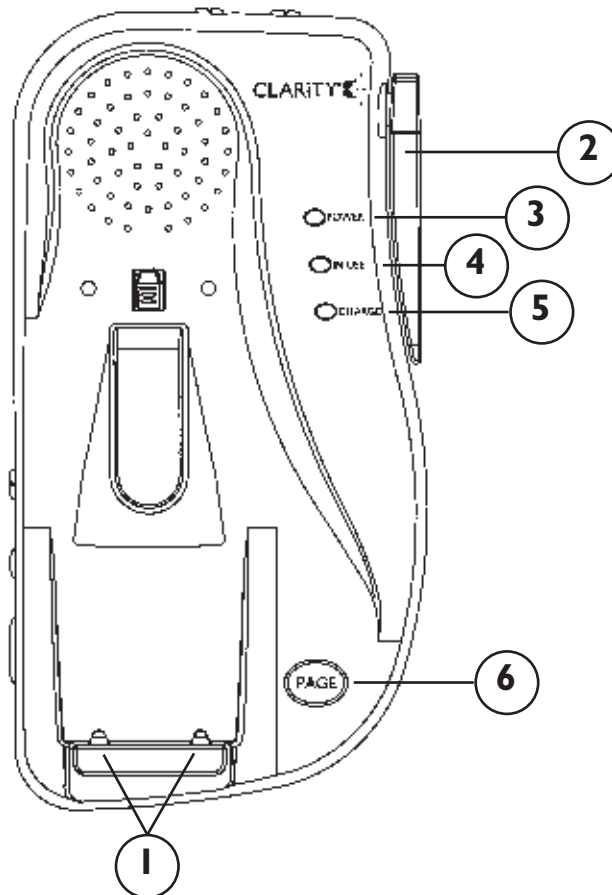

Features

Base Side/End/Bottom

- 1. Ringer Off/On
- 2. Ring Style
- 3. Volume Up/Down
- 4. PULSE/TONE
- 5. BOOST ON/OFF
- 6. AC (Electrical) Adapter Jack
- 7. Telephone Line Jack

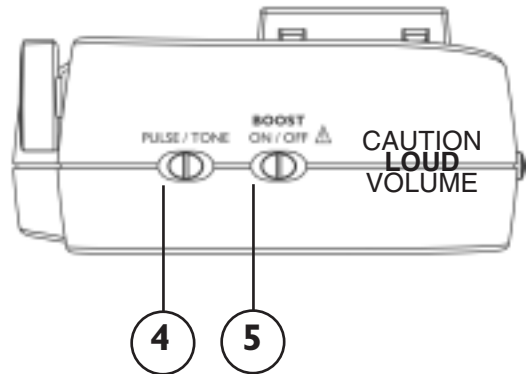
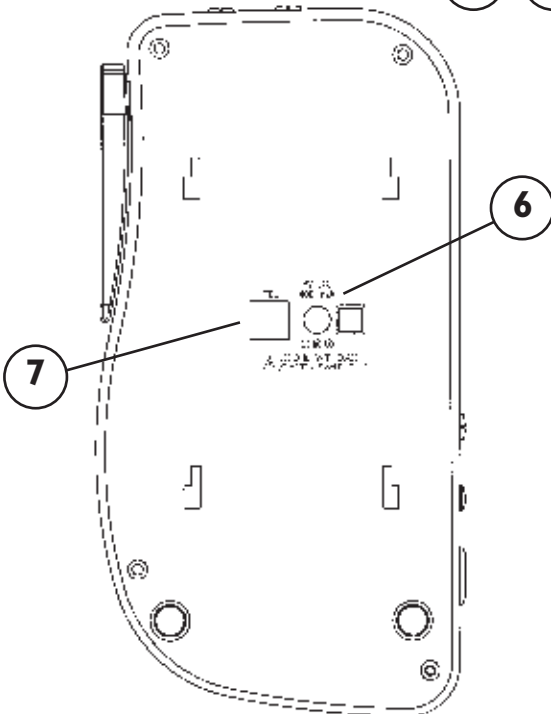
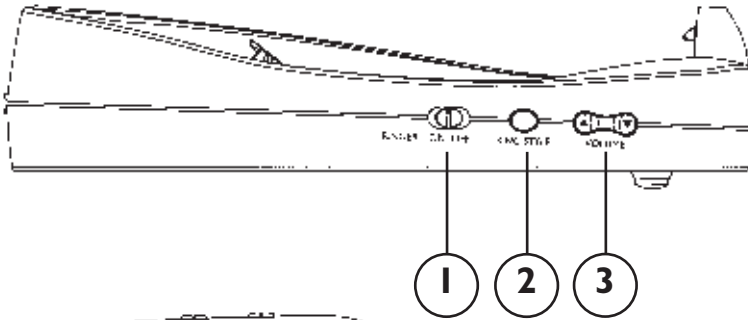

Getting Started

CHOOSING A LOCATION

1. This phone requires a modular phone jack (RJ11C) and a standard 120V AC wall outlet.
2. Plug the AC Adapter directly into outlet.
3. Do not plug other appliances into the same outlet or have outlet controlled by a wall switch.
4. Choose a location that is out of the way of normal activities.

⚠CAUTION: USE ONLY WITH CLASS 2 (CLASSE 2) POWER SOURCE 9V DC, 400mA.

Always connect the AC Adapter to the phone before you connect it to the AC power. When you finish, disconnect the AC power before you disconnect it from the phone.

INSTALLATION

Connecting Your Telephone

Carefully remove your cordless telephone from its box. If there is any visible damage, do not attempt to operate this equipment. Return it to the place of purchase.

Check to be sure that you have all items that come with your telephone. You should have a **HANDSET, BASE UNIT, BATTERY, AC ADAPTER, TELEPHONE LINE CORD, BELT CLIP AND OWNERS MANUAL.**

If at any time you have questions about your telephone please contact our Customer Service Department at: 1-800-552-3368 or 423-622-7793.

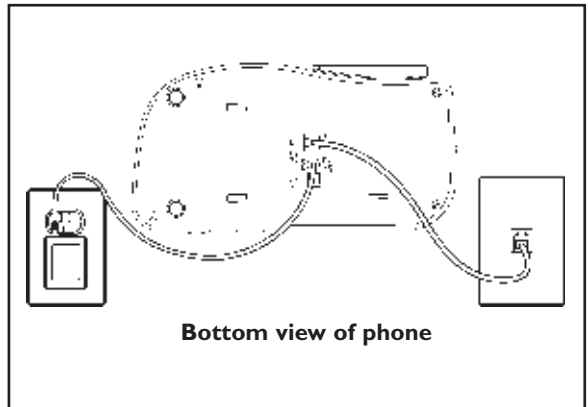

Table/Desktop Installation

CAUTION: Disconnect the telephone line cord before connecting or disconnecting the battery backup in the wall mount bracket.

1. Plug one end of the supplied modular telephone line cord into the jack marked **TEL** located on the back of the telephone base as shown in the diagram.
2. Plug the modular telephone line cord's other end into a modular phone jack.
3. Insert the supplied AC Adapter's plug into the jack marked 9V DC 400mA located on the back of the telephone base.
4. Plug the adapter into a standard 120V AC power (electrical) outlet.

Getting Started

5. Align the mounting bracket on the back of the base so that the black rubber feet are towards the bottom of the phone. Insert the bracket's tabs into the slots and secure the bracket by sliding it upward.
6. Lift the base's antenna to a vertical position.
7. Set the TONE/PULSE switch located on the back of the base to correct dialing mode. Please check with your local Phone Company if uncertain of the type of service.
8. Place handset in the cradle to begin initial charging.
3. Align the mounting bracket on the back of the base so that the black rubber feet are towards the bottom of the phone. Insert the bracket's tabs into the slots and secure the bracket by sliding it upward.
4. Plug the short modular telephone line cord into the wall plate jack, then align the mounting bracket's keyhole slots with the wall plate studs and slide the base of the phone downward to secure it on the wall.
5. Plug the adapter into a standard AC power (electrical) outlet.
6. Press and lift out the handset holder tab, turn it around so the narrow tab end extends out and slide back into its slot. This will hold the handset in the cradle when the phone is wall mounted.
7. Lift the base's antenna to a vertical position.
8. Set the Tone/Pulse switch located on the end of the base to correct dialing mode. Please check with your local Phone Company if uncertain of the type of service.
9. Place handset in the cradle to begin initial charging. Remember, you must charge the phone for at least 12 hours before you use the phone for the first time.

WALL MOUNTING INSTRUCTIONS

CAUTION: Disconnect the telephone line cord before connecting or disconnecting the battery backup in the wall mount bracket.

The base unit may be mounted on a standard wall plate.

1. Plug one end of the supplied short modular telephone line cord into the **TEL** jack located on the back of the base of the phone.
2. Insert the plug of the AC adapter into the jack marked DC 9V 400mA located on the back of the telephone base.

Getting Started

Note: Remember, you must charge the phone for at least 12 hours before you use the phone for the first time.

BATTERY INSTALLATION

The C600 uses a 3.6Volt 600mAh NiMH rechargeable 3 cell (AAA Type) battery that is included with your unit.

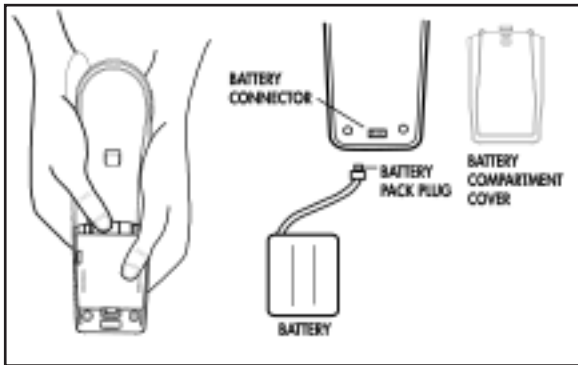

Installing and Connecting Battery

Handset Battery Must be Connected Before Beginning Initial Charging

To connect battery, remove battery compartment cover and connect battery pack plug into the battery connector and replace the battery compartment cover.

Note: The battery in the handset must be fully charged for 12 hours before using the telephone for the first time.

To Install a New Battery:

1. Remove battery cover
2. Install new battery
3. Connect battery pack

4. Replace battery cover
5. Charge for 12 hours before first use

Handset Battery Charging

1. Place the handset in the base. The **CHARGE LED** on the base will light **RED**.
2. After the batteries are fully charged, check for dial tone by pressing **TALK** on the handset.

Low Battery

When the handset battery gets low, there will be two (2) beeps every thirty (30) seconds and the LCD screen will show **BATTERY LOW**. If the battery becomes low while you are on a call, you will be disconnected after about two (2) minutes. Terminate the call and recharge the battery. To recharge the battery pack, place the handset in the base.

The battery charge can also be monitored via the battery charge icon. This icon appears while the phone is in the stand by mode and indicates the condition of the batteries.

1. Make sure the contact points are touching and the **CHARGE LED** is lit.
2. Be careful not to short battery with conducting materials such as rings, bracelets and keys.

Battery Life

A fully charged battery provides an average talk time of about four (4) hours, or standby time of about (8) days.

Talk time and standby time may vary depending on operating conditions.

Getting Started

Headset Jack

You can use this telephone hands-free when you install a 2.5 mm headset (purchased separately). To install, plug the headset into the **HEADSET JACK** at the top of the handset.

While in headset mode, the volume of headset is controlled by the telephone and the handset's earpiece and microphone are disconnected.

Ordering a Headset: In the event you wish to purchase a headset for your C600, please contact Plantronics at 1-800-544-4660 for location near you. We recommend using the Plantronics M110 or M130 headset.

Belt Clip

You may choose to use the optional belt clip with your handset.

1. To attach slide belt clip down onto grooves. Press the tabs on the belt clip into the slots to attach.
2. To remove, lift one side of the belt clip with your thumbnail and push back.

Hearing Aid Compatibility

The handset has a special coil inside of it to couple the sound to hearing aids equipped with T-Switches/T-Coils.

Feature Set-up

CALLER ID DISPLAY

Set-up Mode

C600 handset goes into setup mode automatic when battery is connected.

Or press and hold **MODE** button for 3 seconds to enter setup mode. If there is no input within 30 seconds, the language will be set to the last selected one and go back to standby mode.

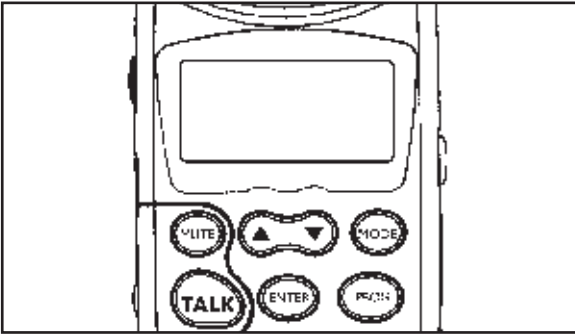

Caller ID Screen

Setting Language

1. After entering setup mode, the **LCD** display will show **SEL LANGUAGE** and then **1.ENG 2.SPA** alternately with a tick mark against the selected language.
2. Press **1, 2 OR 3** button once to change the language. The tick mark will move against the new selection.
3. Press **UP (▲)** to go to the next menu.

Setting Contrast

There are 3 contrast levels and the default is set to level **2**.

1. After setting the language, press **UP(▲)** key to begin setting contrast.
2. The LCD display will show **LCD CONTRAST** and **1 2 3**.
3. Press the **1, 2 or 3** key to change the level. The current selected level will be highlighted.
4. Press the **UP(▲)** or **DOWN (▼)** button to go to the next menu.

Setting AREA CODE 1

1. After setting Contrast, press **UP (▲)** button to set Area Code **1**.
2. The LCD display will show **“AREA CODE 1 and XYZ** with **X** digit blinking.
3. Enter the area code number using the numeric keys on the handset.
4. Press the **UP (▲)** or **DOWN (▼)** button to go to the next menu.

Setting AREA CODE 2

1. After setting Area Code 1, press **UP (▲)** button to set Area Code **2**.
2. The LCD display will show **AREA CODE 2 and XYZ** with **X** digit blinking.
3. Enter the area code number using the numeric keys on the handset.
4. Press the **UP (▲)** or **DOWN (▼)** button to go to the next menu.

Feature Set-up

Setting LDS CODE

1. After setting Area Code 2, press **UP(▲)** button to set LDS Code.
2. The LCD display will show **LDS CODE** and **X** with **X** digit blinking.
3. Enter the LDS number using the numeric keys on the handset.
4. Press the **UP(▲)** or **DOWN(▼)** button to go to the next menu.

Setting EASY MODE

1. After setting LDS Code, press **UP (▲)** button to set the Easy Mode.
2. The LCD display will show **EASY MODE** and **1.ON 2.OFF**.
3. Press **1** or **2** to change the mode. The tick mark will move against the selected mode.
4. Press the **UP (▲)** or **DOWN (▼)** button to change the mode.

Setting VOICEMAIL NO

1. After setting Easy Mode, press **UP(▲)** button to set **VOICEMAIL** Number.
2. The LCD display will show **VOICEMAIL NO** and **XXX-XXX-XXXX** with the last digit blinking.
3. Enter the voicemail number using the numeric keys on the handset. Press **DEL/CH** key to delete and move cursor back one place.
4. Press the **UP (▲)** or **DOWN (▼)** button to go to the next menu.

Setting MESSAGE WAITING ON/OFF

1. After setting Voicemail No, press **UP (▲)** button to set Message Waiting function on/off.
2. The LCD display will show **MESSAGE, WAITING**, and **1.ON 2.OFF** with a tick mark against the selected item.
3. Press **1** or **2** button to change the mode.
4. Press the **UP (▲)** or **DOWN (▼)** button to go to the next menu.

Setting AUTOCONNECT ON/OFF

1. After setting Message Waiting Light Off, press **UP (▲)** button to set **AUTOCONNECT ON/OFF** (default to ON).
2. The LCD display will show **AUTOCONNECT, 1.ON 2.OFF**.
3. Press **1** or **2** to change or current selected value. The tick mark will move against the selected value.
4. Press the **UP (▲)** or **DOWN (▼)** button to go to the next menu.

Feature Set-up

Clarity Power Technology

With the Clarity Power feature, the high frequency sounds are amplified more than the low frequency sounds so words are not just louder, but clearer and easier to understand.

BOOST Clarity Power On/Off

The C600 has a button that controls the loudness of the receiver. Once the **BOOST** button is pressed, an extra level of amplification is added over the entire range of the volume control.

The **TALK** button will light **ORANGE** to indicate the **CLARITY POWER** feature is activated.

WARNING: When the **TALK** button is lit **ORANGE** volume may be at a high level. To protect hearing, lower the volume control to minimum before using.

Volume Control

The dial controls the level of volume the hand-set and headset receive. The volume dial provides up to 15 dB of volume before the **CLARITY POWER** button is activated. Once the **CLARITY POWER** button is pressed, the C600 will provide up to 30 dB of gain.

Handset Ringer

Set the switch marked Ringer **ON/OFF** located on the side of the handset. The ringer switch must be set to **ON** for the handset to ring.

NOTE: If both handset and base ringer s are set to OFF, the visual ringer will flash to indicate there is an incoming call.

TELEPHONE BASE

Ringer Volume

The base ringer volume adjustments are located on the side of the telephone base.

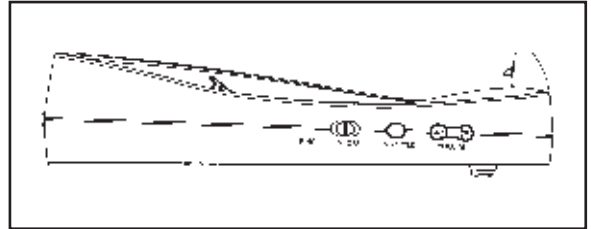

Telephone Base

Pressing the **UP** (**▲**) key on the base increases the ringer sound by one level while pressing the **DOWN** (**▼**) key reduces the sound by one level. There are a total of six levels from maximum to minimum.

The ringer will sound for two (2) seconds while choosing a ringer volume, to allow the user to make a choice.

Ringer Style

The base ringer style adjustments are located on the side of the telephone base.

The style of ring can be adjusted by pressing the **RING STYLE** button. Six (6) styles are available allowing you to customize your ring. The ringer will sound for 2 seconds while choosing a ringer style, to allow the user to make a choice.

Visual Ringers

Visual ringers are located in both the handset antenna and the base of the telephone.

Feature Set-up

When an incoming call is received, these lights will flash. The handset visual ringer will also stay lit while the phone is in use.

BOOST ON/OFF Switch

This switch will disable the reset feature of the **BOOST** Clarity Power button as follows:

ON —When the Boost **ON/OFF** switch is set to “**ON**”, the Boost function will be **ON** every time a call starts, and will default to **ON** every time the phone hangs up. During a call, the **BOOST** Clarity Power button can toggle the Clarity Power **ON** or **OFF** according to the user's needs.

OFF —When the Boost **ON/OFF** switch is set to “**OFF**”, the Boost function (Clarity Power) will be **OFF** every time a call starts, and the user will need to press the **BOOST** Clarity Power button in order to gain the extra level of amplification. If the phone hangs up, the Clarity Power will reset to **OFF**. During a call, the **BOOST** Clarity Power button can toggle the Clarity Power function on or off according to the user's needs.

Pulse/Tone

Slide the switch to the type of telephone service you have; tone for touch-tone service or pulse for rotary dialing. Please check with your local telephone company if uncertain of the type of service.



CAUTION: VOLUME WILL BE LOUD WHEN BOOST SWITCH IS SET TO “ON”.

Flash

The **FLASH** button is activated to use custom calling services such as Call Waiting or Three Way Calling. Please contact your local telephone company for information on these services.

Mute

The **MUTE** button allows the user to conduct a private conversation that you do not want the person on the other end to hear. While in the mute mode, the **MUTE** button will illuminate **RED** and the microphone in the handset is disabled. Pressing the **MUTE** button again will disengage the **MUTE** feature.

Redial/Pause

The **RD/P** button both the last number redial and the pause feature.

Battery Backup

Installing four (4) AA Alkaline batteries into the desk/wall mount bracket attached to the telephone base will offer you a limited amount of time to continue operating your telephone in the event of a power failure.

To Install Battery Backup Batteries:

1. Disconnect telephone line cord and remove desk/wall mount bracket from telephone base
2. Disconnect battery backup connector from the telephone base
3. Install four (4) AA Alkaline batteries with negative (-) end of battery touching the spring
4. Connect battery backup connector to terminal on bottom of telephone base
5. Install desk/wall mount bracket to telephone base

Telephone Operations

To Replace Battery Backup Batteries:

1. Disconnect telephone line cord and remove desk/wall mount bracket from telephone base
2. Disconnect battery backup connector from the telephone base
3. Remove batteries from desk/wall mount bracket
4. Install four (4) AA Alkaline batteries with negative (-) end of battery touching the spring
5. Connect battery backup connector to terminal on bottom of telephone base
6. Install desk/wall mount bracket to telephone base

After installing the four (4) AA Alkaline batteries please refer to the chart below:

Power Supply	Power LED Status
AC adapter and good batterieis	Steady green
AC adapter and no batterieis	Steady red
AC adapter and bad batterieis	Flashing green and red
Power failure and good batterieis	Slow flashing red
Power failure and bad batterieis	Fast flashing red

Placing a Call

1. Press the **TALK** button (TALK button will illuminate **GREEN**) and dial the number you wish to call.
2. To end the call press the **TALK** button or place the handset in the base.
Or
 1. Press the keys of the numbers needed to dial. The **LCD** will display **PREDIAL** and the keys pressed.
 2. Press the **TALK** button. Handset will go off-hook and dialed the displayed numbers.

Answering a Call

If the handset is out of the cradle, press the **TALK** button.

If the handset is in the cradle with Auto-Connect Mode **ON**, lift the handset. The handset will be in receiver mode.

If the handset is in the cradle with AutoConnect mode **OFF**, lift the handset. The handset will be in standby mode. Press **TALK** button to receive the call.

Refer to **BOOST** Clarity Power and Volume Control for information on adjusting volume controls on Pages 13-19.

Last Number Redial:

The last number dialed (up to 32 digits) is stored in the redial memory until another number is dialed.

To use this feature:

1. Press the **TALK** button.
2. When you hear the dial tone, press the **RD/P** button.
3. The phone will automatically dial for you.

Pause Feature:

Programming in a pause will cause the phone to wait four (4) seconds before dialing additional numbers. This feature may be used when it is necessary to dial an access code (9, for example) and wait for a second dial tone before you can dial an outside number. Press the **RD/P** button at the required point during the memory storage process to program a pause.

Telephone Operations

Temporary Tone

If you have rotary (pulse) dial service, you can change from pulse to touch tone (tone) during a call.

1. Make phone call and wait until it is connected.
2. Press the * key. Keys pressed after this are sent as tone signals.
3. The phone will automatically reset to rotary (pulse) service after the call ends.

Lighted Key Pad

The key pad will light for fifteen (15) seconds after removing the handset from the base. To reactivate the feature while in standby, press the **TALK** or the **MEM** button. To activate while the phone is in use, press any key.

Page/Handset Locator

To send a page signal from the base to the handset, press the **PAGE** button located on the base of the telephone. A series of rings will sound from the handset.

To locate the handset if it is away from the base, press and hold the **PAGE** button for approximately five (5) seconds. A series of rings will sound. Return the handset to the base or press any button to cancel the page.

Channel Operation

The C600 cordless telephone automatically searches and selects the clearest of 40 channels when it is being used. If interference develops on the line, pressing this button will move to another channel.

Security Code

The security code prevents your cordless phone conversations from being accessed by a phone on a different line. Once the handset battery is fully charged, the handset will automatically select the code from over 65,000 different combinations. The code is changed every time the handset is placed in the cradle.

If you have trouble with placing or receiving calls, a lost security code may be the cause of the problem. When this occurs, the handset can no longer communicate with the base.

Memory Storage

Reset by placing the handset on the base for 5-10 seconds. If that does not work, unplug the AC adapter from the wall outlet. Disconnect the handset battery for 5-10 seconds, and then reconnect. Place hand-set back on the base and then reinsert the AC adapter.

MEMORY OPERATIONS

Review Phonebook Information

1. Unit must be in standby mode only.
2. Press **MODE** key twice. The LCD will show **PHONEBOOK**.
3. If the phonebook is empty, after 1 second the display shows - **NO RECORDS** -.
4. Otherwise, the display will show the first alphabetical record with the record number on the top icon line. The record number may not be the first one.
5. Press the **UP** (▲) or **DOWN** (▼) button to go to the next record. Or select any other alphabetical list pressing 2 to 9 key.
6. When at the end of phonebook list, pressing **DOWN** (▼) button will show **END OF LIST**. Press **UP** (▲) button to go to the last record.

Adding a Phonebook Number

1. Unit must be in standby mode only.
2. Press **MODE** key twice. The display will show **PHONEBOOK** for 1 second and then display the first available record.

3. Press **PROG** key to add new phone record.
4. If the phonebook is full, the display will show **PHONEBOOK FULL** for 1 second together with an error keynote. Then return to review mode.
5. If memory is available, the display will show **SAVE NEW NUM** and then **ENTER NUMBER**.
6. After pressing any number key, the second line will change to **ENTER TO END** and the third line shows the number(s) pressed. Enter phone number up to 23 digits, (**RD/P** treated as Pause, counted as one digit, shown as **P**). Press **DEL/CH** to erase any mistake.
7. Press **ENTER** to confirm number. The **LCD** will display **ENTER NAME** and then the second line is blanked.
8. Enter name up to 21 characters using key **2** to **9**.
 - Press **2** once for **A** and twice for **B**.
 - Press **#** to insert **#** or punctuation marks.
 - Use **RD/P** key to insert a space between alphabets.
 - Press **DEL/CH** key to erase any mistake.
 - The cursor will move forward one space automatically.
9. Press **ENTER** to confirm name. The **LCD** will display **NUMBER STORED**. Then it displays the just entered information.

Memory Storage

Dialing a Phonebook Entry

1. Locate the phonebook record you wish to call.
2. Press **TALK** or **ENTER** button to dial the displayed number.

Deleting a Stored Number

1. Unit must be in standby mode and display is showing a phonebook record.
2. Press **DEL/CH** key once. The LCD will show **DELETE?**
3. Press **DEL/CH** to confirm.
4. The display will show **MEM DELETED** for 3 seconds together with a success keynote.
5. The display will show the next available record or **-NO RECORDS-**.

- If the memory location is empty, pressing **DEL** key will have no action.
- This sequence will time-out after 30 seconds if no key is pressed.

Deleting All Stored Numbers

1. Unit must be in standby mode and display is showing a valid phone record.
2. Press and hold **DEL/CH** button for 3 seconds to delete all phonebook records. Display will flash **DELETE ALL?**
3. Press **DEL/CH** to confirm. Display will show **-NO RECORDS-** for 2 seconds together with a success keynote.

- If the memory location is empty, pressing **DEL** key will have no action.
- This sequence will time-out after 30 seconds if no key is pressed.

Changing a Memory Number

1. Unit must be in standby mode only.
2. Press **MODE** key twice. The display will show **PHONEBOOK** for 1 second and then display the first available record.
3. Press the **UP(▲)** or **DOWN(▼)** button to go to the record to be changed, e.g. **ABC, 567**
4. Press **# KEY** to change the phone record.
5. The display will show **ENTER TO END** and the stored number **567** with the blinking cursor after the digit **7**.
6. Press any numeric key to add extra numbers.

Or

Press **DEL/CH** key to move the cursor to the digit **7**. Then press other numeric key to replace **7**.

7. Press **ENTER** after finishing the digits.
8. The display shows **ABC** with the cursor blinking after the character **C**.
9. Press any numeric key **2** to **9** to add extra characters.

Or

Memory Storage

Press **DEL/CH** key to move the cursor back to character **C**. Then press any other numeric key to change this character.

10. Press **ENTER** to finish. The modified characters and numbers will replace the original phone record.

11. The display will show **NUMBER STORED**.

Adding the **EMERGENCY** Number

1. Unit must be in standby mode only.
2. Press **MODE** key twice. The display will show **PHONEBOOK** for 1 second and then display the first available record.
3. Press the **UP(▲)** or **DOWN(▼)** button to go to the record to be stored to the **EMERGENCY** key.
4. Press and hold the **EMERGENCY** key for 2 seconds.

5. The phone number is copied to the **EMERGENCY** key. The LCD will display **MEM STORING** for one (1) second and the handset will give a success keynote.

Dialing the **EMERGENCY** Number

1. Unit must be in standby mode only.
2. Press the **EMERGENCY** key once.
3. The display will show the stored name and number for 5 seconds. Otherwise it will show **-MEMORY EMPTY-**.
4. Then the handset goes off-hook and dial out the stored numbers.

Or

5. Press **TALK** key to make handset goes off-hook.
6. Press the **EMERGENCY** key once. The display will show the stored name and number for 1 sec. Then the numbers will be sent out.

Deleting the **EMERGENCY** Number

1. Unit must be in standby mode.
2. Press the **EMERGENCY** key once.
3. If this key has been programmed, the display will show the stored number. Otherwise, it will show **MEMORY EMPTY**.
4. Press **DEL/CH** key once to delete this number.
5. The display will flash **DELETE ?**.

Caller ID Operations

6. Press **DEL/CH** to delete. The handset will give a success keynote and the display will show **MEM DELETED**.

VISUAL MESSAGE WAITING INDICATOR (VMWI)

NOTE: This is a service that is provided through your local telephone company.

If the C600 finds that there is voice message to be retrieved, it will turn on the Message Waiting Indicator (the **ENTER** key).

To retrieve the voice message, press the **ENTER** key while the indicator is on. The handset will go off-hook and dial the stored Voicemail number.

CALLER ID INFORMATION

This function is turned off when **EASY MODE** is set to **ON** during setup.

Caller Information

When somebody calls, the received caller information is displayed on the **LCD**. If the call is answered by this phone, this caller information is considered **old**. Otherwise, the Caller ID information will be stored in the call log. Information which has not been reviewed will be considered as **new call**.

The **NEW CALL** LED will blink. The top row displays the time and date of the call. The second row displays the caller's ID or is blank if there is no information. The third row displays the incoming telephone number. If the number is

longer than twelve (12) digits, the LCD will toggle the displayed number between the first 12 digits and the remaining digits.

Receiving Call Waiting Caller ID

When you are on an existing call, you will hear a beep and the display will show incoming call waiting Caller ID information.

If you access the call waiting call, the Caller ID information will disappear and the Time/Day screen will appear.

If you do not access the call waiting call, the Caller ID information will be transferred into the Caller log. This caller information is considered **old**.

Unknown Call

If a call is from another country or the caller's number is not available, **UNKNOWN** is displayed and stored in the Caller ID log.

Blocked Call

If the number is blocked or withheld, **PRIVATE** is displayed and stored in Caller ID log.

Repeated Call

If this is a repeated call, it means the same number called before and has not been reviewed.

CALLER ID Review

If there is new call information, the **MODE** button will flash **RED**.

During standby mode, press **MODE** button once. **LCD** will display **CID MODE** and then

Caller ID Operations

the last Caller ID information.

Press **UP (▲)** or **DOWN (▼)** again to view the Caller ID content. Press **DOWN (▼)** to scroll the caller ID information from the most recent record. Or, press the **UP (▲)** button to scroll the Caller ID information from the oldest record.

If the caller's number is more than (12) digits, the LCD will toggle the displayed message between the first 12 digits and the remaining digits.

If the Caller ID list is empty, the display will show - **NO CALLS** -.

- At anytime, the user can press **FLASH** button one time to go back to standby mode.

Or

- It will go back to standby automatically at 30 seconds time out if there is no action.

SAVING CALLER ID INFORMATION TO PHONEBOOK

1. While reviewing Caller information, press **PROG** key once.
2. The display shows **SAVE TO, PHONEBOOK**. Then it changes to

ENTER TO END, and the Caller number on the third line with the blinking cursor at the end of the number.

3. Use numeric key to add extra numbers. Press **DEL/CH** to erase any mistakes.

Or

Press **DEL/CH** to move cursor back one digit. Then press any other numeric key to replace the number.

4. Press **ENTER** to confirm the number.
5. The display shows **ENTER NAME** first and then the Caller's name on the second line with blinking cursor at the end. The entered number is displayed on the third line.

6. Press **2 9** keys to add extra characters. Press **DEL/CH** to erase any mistakes.

Or

Press **DEL/CH** to move cursor back one character. Then press any other numeric key to replace the character.

7. Press **ENTER** to confirm the name.
8. The display will show **NUMBER STORED** first. Then it shows the name and number just saved.

- At anytime, user can press **FLASH** button one time to go back to standby mode, OR

- It will go back to standby automatically at 30 seconds time out if there is no action.

CALLBACK FROM CALLER ID

Caller ID Operations

INFORMATION

To callback from incoming call information, the base **T/P** switch should be set at **T**.

While reviewing the incoming call list, press **ENTER** and the **UP(▲)** or **DOWN(▼)** key will format the number with the following dialing variations:

7 digits without a 1 prefix:

If the area code of the Caller ID number matches to the setting of the stored area code, the dialed numbers can be 7 digits only.

Area Code + 7 digits without a 1 prefix:

If the area code of the Caller ID number matches to the setting of the stored area code, the dialed numbers can be Area Code + 7 digits.

10 digits without a 1 prefix:

If the area code of the Caller ID number is different from the stored area code, the dialed numbers can be 10 digits without a 1 prefix.

10 digits with a 1 prefix:

If the area code of the Caller ID number is different from the stored area code, the dialed numbers can be 1 + 10 digits.

When reviewing the Caller ID information, press **ENTER** to display the phone number in a different format.

Example 1:

Stored Long Distance Service code: **1**.

Stored area code: 770.

Stored incoming call number 770-123-4567.

1. Pressing the **ENTER** key will show blinking **123-4567**.

2. Pressing the **TALK** or **ENTER** key again will dial out **1234567**.

OR

3. Pressing the **UP(▲)** key will show blinking **770-123-4567**. Then press the **TALK** or **ENTER** key again will dial out **7701234567**.

OR

4. Pressing the **UP(▲)** key will show blinking **1-7701234567**. Press the **TALK** or **ENTER** key will dial out **17701234567**.

OR

5. Pressing the **UP(▲)** key will show blinking **123-4567** again.

Example 2:

Stored Long Distance Service code: **1**.

Stored area code: 770.

Stored incoming call number 413-456-7890.

1. Pressing the **ENTER** key will show blinking **413-456-7890**.

Caller ID Operations

2. Pressing the **TALK** or **ENTER** key again will dial out **4134567890**.

OR

3. Pressing the **UP(▲)** key will show blinking **1-4134567890**. Press **TALK** or **ENTER** key will dial out **14134567890**.

OR

4. Press **UP (▲)** key will show blinking **413-456-7890** again.

DELETE CALLER ID INFORMATION

Delete One Caller ID Information

While reviewing the Caller ID, press **DEL/CH** button to delete the displayed caller information. **LCD** will flash **DELETE ?**.

Press **DEL/CH** to confirm. **CID DELETED** will be displayed for 2 seconds.

The next record is shown automatically or **- NO CALLS -** if the list is empty.

- At anytime, user can press **FLASH** button one time to go back to standby mode.

Or

- It will go back to standby automatically at 30 seconds time out if there is no action.

Deleting All Caller ID Information

While reviewing the Caller ID, press and hold the **DEL/CH** button for two seconds. **LCD** will flash **DELETE ALL ?**.

Press **DEL/CH** to confirm.

LCD will display **ALL CID** and **DELETED** for 2 seconds and then **- NO CALLS -**.

- At anytime, user can press **FLASH** button one time to go back to standby mode. Or
- It will go back to standby automatically at 30 seconds time out if there is no action.

Maintenance and Care

The C600 has been designed to give you years of dependable service with a minimum of care.

To ensure the utmost in performance, follow these guidelines in caring for the unit:

1. Avoid dropping or knocking the unit.
2. Dust the unit regularly. Wipe the unit with a soft damp cloth.
3. Do not use detergents and avoid excess moisture.
4. The C600 is an electrical device. Avoid electric shock by keeping the phone away from water (i.e. bath room, kitchen sink, etc.)

Troubleshooting

The unit will not operate/no dial tone:

- ✘ Verify the TALK Button is lit.
- ✘ Verify the AC Adapter is securely plugged into AC outlet, the base and the telephone.
- ✘ Verify the telephone line cord is securely plugged into the wall jack and the telephone.
- ✘ Make sure the base antenna is in an upright position.
- ✘ Make sure the handset battery is fully charged.
- ✘ Verify the telephone is in the correct dialing mode, tone (touch) or pulse (rotary).
- ✘ Make sure you are in the usable range of the base station.
- ✘ Reset the security code by placing the handset in the base for 5-10 seconds.

The phone does not ring when you receive a call:

- ✘ Make sure the RINGER switch on the handset and base are set to ON.
- ✘ Verify the AC Adapter is securely plugged into AC outlet, the base and the telephone.
- ✘ Verify the telephone line cord is securely plugged into the wall jack and the telephone.
- ✘ Make sure you are in the usable range of the base station.
- ✘ You may have too many extensions on your line. Try unplugging a few devices.

Noise, Static, Interference or Other Calls Heard while Using the Handset:

- ✘ Try changing channels.
- ✘ Make sure the base antenna is in an upright position.
- ✘ Make sure you are in the usable range of the base station.
- ✘ Make sure the handset battery is fully charged.
- ✘ Try relocating the base unit to another location.
- ✘ Make sure the AC Adapter is not plugged into the wall outlet with other appliances.

Troubleshooting

Phone Will Not Hold Charge:

- ✧ Make sure the charging contacts on the handset and base are free of dust and dirt. Clean the contacts with a soft cloth.
- ✧ Make sure CHARGE LED on the base is lit when handset is in the cradle.
- ✧ If necessary, replace the handset battery. (See Handset Battery Charging)

Difficulty in Placing or Receiving Calls:

- ✧ Move closer to the base and try again.
- ✧ If moving closer does not work, you may have lost the security code.
- ✧ Reset code by placing the handset back on the base for 5-10 seconds. (See Security Code Section)
- ✧ Make sure you have selected the correct dialing mode, tone or pulse.
- ✧ Make sure the AC Adapter is not plugged into a wall outlet with other appliances. Disconnect for 5-10 seconds then reconnect. Place the handset back on the base and reinsert the AC Adapter.
- ✧ Make sure the handset battery is fully charged.

Regulatory Compliance

Part 68 of FCC Rules Information

a) This equipment complies with Part 68 of the FCC rules and the requirements adopted by the ACTA. On the bottom of this equipment is a label that contains, among other information, a product identifier in the format US:AAAEQ##TXXXX. If requested, this number must be provided to the telephone company.

b) A plug and jack used to connect this equipment to the premises wiring and telephone network must comply with the applicable FCC Part 68 rules and requirements adopted by the ACTA. A compliant telephone cord and modular plug, RJ11 C USOC, is provided with this product. It is designed to be connected to a compatible modular jack that is also compliant. See installation instructions for details.

c) The REN is used to determine the number of devices that may be connected to a telephone line. Excessive RENs on a telephone line may result in the devices not ringing in response to an incoming call. In most but not all areas, the sum of RENs should not exceed five (5.0). To be certain of the number of devices that may be connected to a line, as determined by the total RENs, contact the local telephone company. For products approved after July 23, 2001, the REN for this product is part of the product identifier that has the format US:AAAEQ##TXXXX. The digits represented by ## are the REN without a decimal point (e.g., 03 is a REN of 0.3). For earlier products, the REN is separately shown on the label.

d) If this telephone equipment causes harm to the telephone network, the telephone company will notify you in advance that temporary discontinuance of service may be required. But if advance notice isn't practical, the telephone company will notify the customer as soon as possible. Also, you will be advised of your right to file a complaint with the FCC if you believe it is necessary.

e) The telephone company may make changes in its facilities, equipment, operations or procedures that could affect the operation of the equipment. If this happens the telephone company will provide advance notice in order for you to make necessary modifications to maintain uninterrupted service.

f) If trouble is experienced with this telephone equipment, for repair or warranty information, please contact Clarity, 1-800-552-3368. If the equipment is causing harm to the telephone network, the telephone company may request that you disconnect the equipment until the problem is resolved.

g) This telephone equipment is not intended to be repaired and it contains no repairable parts. Opening the equipment or any attempt to perform repairs will void the warranty. For service or repairs, call 1-800-552-3368.

h) Connection to party line service is subject to state tariffs. Contact the state public utility commission, public service commission or corporation commission for information.

Regulatory Compliance

i) If your home has specially wired alarm equipment connected to the telephone line, ensure the installation of this telephone equipment does not disable your alarm equipment. If you have questions about what will disable alarm equipment, consult your telephone company or a qualified installer.

j) This telephone equipment is hearing aid compatible.

Customer-Owned Coin/Credit Card Phones:

To comply with state tariffs, the telephone company must be given notification prior to connection. In some states, the state public utility commission, public service commission or corporation commission must give prior approval of connection.

Part 15 of FCC Rules Information

This device complies with Part 15 of the FCC Rules. Operation is subject to the following two conditions: (1) This device may not cause harmful interference, and (2) this device must accept any interference received, including interference that may cause undesired operation.

Your equipment has been tested and found to comply with the limits of a Class B digital device, pursuant to Part 15 of FCC rules. These limits are designed to provide reasonable protection against harmful interference in residential installation.

This equipment generates, uses and can radiate radio frequency energy and, if not installed and used in accordance with the instructions, may cause harmful interference to radio communications. However, there is no guarantee that interference will not occur in a particular installation; if this equipment does cause harmful interference to radio or television reception, which can be determined by turning the equipment off and on, you are encouraged to try to correct the interference by one of the following measures:

1. Where it can be done safely, reorient the receiving television or radio antenna.
2. To the extent possible, relocate the television, radio or other receiver with respect to the telephone equipment. (This increases the separation between the telephone equipment and the receiver.)
3. Connect the telephone equipment into an outlet on a circuit different from that to which the television, radio, or other receiver is connected.
4. Consult the dealer or an experienced Radio/TV Technician for help.

CAUTION: Changes or modifications not expressly approved by the manufacturer responsible for compliance could void the user's authority to operate the equipment.

Regulatory Compliance

Industry Canada Technical Specifications

This product meets the applicable Industry Canada technical specifications.

Before installing this equipment, users should ensure that it is permissible to be connected to the facilities of the local telecommunications company. The equipment must also be installed using an acceptable method of connection. In some cases, the company's inside wiring associated with a single line individual service may be extended by means of a certified connector assembly (telephone extension cord). The customer should be aware that compliance with the above conditions may not prevent degradation of service in some situations.

Repairs to certified equipment should be made by an authorized Canadian maintenance facility designated by the supplier.

Any repairs or alterations made by the user to this equipment, or equipment malfunctions, may give the telecommunications company cause to request the user to disconnect the equipment.

Users should ensure for their own protection that the electrical ground connections of the power utility, telephone lines and internal metallic water pipe system, if present, are connected together. This precaution may be particularly important in rural areas.

CAUTION: Users should not attempt to make such connections themselves, but should contact the appropriate electrical inspection authority, or electrician, as appropriate.

The Ringer Equivalence Number is an indication of the maximum number of terminals allowed to be connected to a telephone interface. The termination on an interface may consist of any combination of devices subject only to the requirement that the sum of the Ringer Equivalence Numbers of all the devices does not exceed five.

(The term IC: before the certification/registration number only signifies that the Industry Canada technical specifications were met.)

Warranty and Service

The party responsible for regulatory compliance:

Clarity, A Division of Plantronics, Inc.
4289 Bonny Oaks Drive, Suite 106
Chattanooga, TN 37406
Phone: 1-800-552-3368

The following warranty and service information applies only to products purchased and used in the U.S. and Canada. For warranty information in other countries, please contact your local retailer or distributor.

Limited Warranty

Clarity, a division of Plantronics, Inc. (Clarity) warrants to the original consumer purchaser that, except for limitations and exclusions set forth below, this product shall be free from defects in materials and workmanship for a period of one (1) year from the date of original purchase (Warranty Period). The obligation of Clarity under this warranty shall be at Clarity s option, without charge, of any part or unit that proves to be defective in material or workmanship during the Warranty Period.

Exclusions from Warranty

This warranty applies only to defects in factory materials and factory workmanship.

Any condition caused by accident, abuse, misuse or improper operation, violation of instructions furnished by Clarity, destruction or alteration, improper electrical voltages

or currents, or repair or maintenance attempted by anyone other than Clarity or an authorized service center, is not a defect covered by this warranty. Telephone companies manufacture different types of equipment and Clarity does not warrant that its equipment is compatible with the equipment of a particular phone company.

Implied Warranties

Under state law, you may be entitled to the benefit of certain implied warranties. These implied warranties will continue in force only during the warranty period. Some states do allow limitations on how long an implied warranty lasts, so the above limitation may not apply to you.

Incidental or Consequential Damages

Neither Clarity nor your retail dealer or selling distributors has any responsibility for any incidental or consequential damages including without limitation, commercial loss or profit, or for any incidental expenses, expenses, loss of time, or inconvenience. Some states do not allow exclusion or limitation of incidental or consequential damage, so the above limitation or exclusion may not apply to you.

Other Legal Rights

This warranty gives you specific legal rights and you may also have other rights which vary from state to state.

Warranty and Service

How to Obtain Warranty Service

To obtain warranty service, please prepay shipment and return the unit to the appropriate facility listed below.

In the United States

Clarity Service Center
4289 Bonny Oaks Drive, Suite 106
Chattanooga, Tennessee 37406

Tel: (423) 622-7793
or (800) 426-3738

Fax: (423) 622-7646
or (800) 325-8871

In Canada

Clarity Service Center
1455 Pitfield Boulevard
Saint-Laurent
Quebec H4S 1G3

Tel: (800) 540-8363
(514) 956-8363

Fax: (514) 956-1825

Please use the original container, or pack the unit(s) in a sturdy carton with sufficient packing material to prevent damage. Include the following information:

1. A proof-of-purchase indicating model number and date of purchase.
2. Bill-to address.
3. Ship-to address.
4. Number and description of units shipped.
5. Name and telephone number of person to call, should contact be necessary.
6. Reason for return and description of the problem.

Damage occurring during shipment is deemed the responsibility of the carrier, and claims should be made directly with the carrier.